

PTAC AND PTHP UNITS



KTHN
Series



KLIMAIRE[®]
Mark of superior Quality

Comfort Command

Klimaite PTAC and PTHP units are the economical way to cool and heat your room, easy to install and maintain for years of satisfactory use.

Every unit is built with last generation push button control panel on the right hand side of the unit.

Control panel has LED indicators and push buttons for MODE, FAN, POWER and set points UP and DOWN.

The control can display the temperature either in °F or °C. KTHN control panel is designed for simple operation. Controls are easy to read, understand, and activate by the help of LED lights showing current status



EXCEPTIONALLY QUIET OPERATION – SEPARATE OUTDOOR AND INDOR MOTORS

Improved larger diameter indoor tangential fan wheel provides uniform and silent air flow, along with the dual motor configuration contribute to lower noise level for quiet environment.



DIGITAL DISPLAY CONTROL

Every unit is built with standard push button controls and LED display to show the set temperature and operational codes.



EASY TO CLEAN FILTER

Pull out long life washable polypropylene dust collector filter offers effective air filtration and is easy to clean without opening the intake front panel for easy maintenance.

STANDARD WALL THERMOSTAT

A 24 V wall thermostat can be easily hooked up for added convenience.



REMOTE CONTROL

Your unit is equipped with built-in receiver for an optional wireless remote control for convenience and added comfort.

HIGH EFFICIENCY ROTARY COMPRESSOR

Assures super quiet operation for maximum comfort and efficiency.



FRESH AIR INTAKE

An adjustable damper allows fresh air into the living space for a cleaner and fresher room environment comfort. A polypropylene c mesh filter prevents air borne pollutants into living space and easy to clean using mild soap and water, and is suitable and prefer for hospitality, assisted living and residential applications.



POWER CORD

Factory supplied power cord with 3-prong grounding plug and current detection device with reset.



CONVENIENT & RELIABLE ELECTRONIC CONTROLS

Saves money by the controlling the lowest and highest temperature setting by adjusting the set dip switches settings, there are several options to control your Klimaire PTAC and PTHP units, by adding a standard wall thermostat, a wireless remote control, or from the front office.

INDUSTRY STANDARD

Wall sleeve, hence it makes installation easy, economical and quick, either for replacement of existing units or for new construction.

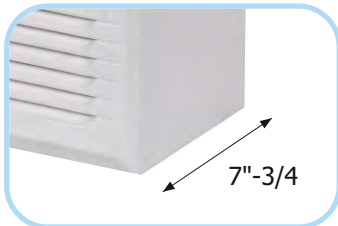

STYLISH SLIM DESIGN

7"-3/4 front depths enhances valuable room space with this sleek unit front.

FRONT OFFICE CONTROL

To efficiently manage all of the rooms at the front desk for energy savings via dip switch configuration.



- All models with supplementary Electric Heater
- Last generation technologies in temperature and humidity control
- Effective air filtration
- Easy cleaning Lifetime filters design
- Ultra quiet operation



Sizes and compatibility:

Sizes according with international standards. Klimaire PTAC units can be installed in any standard 42" W x 16" H wall sleeve.

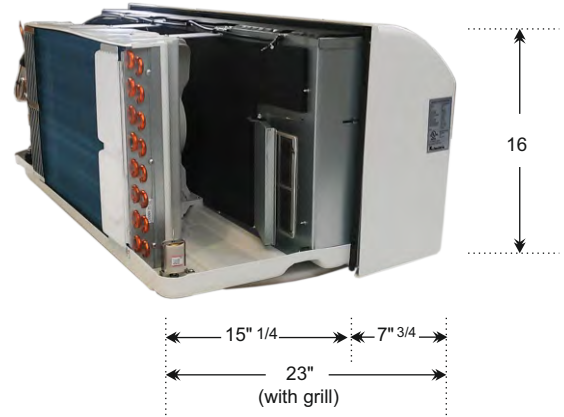

Model Code

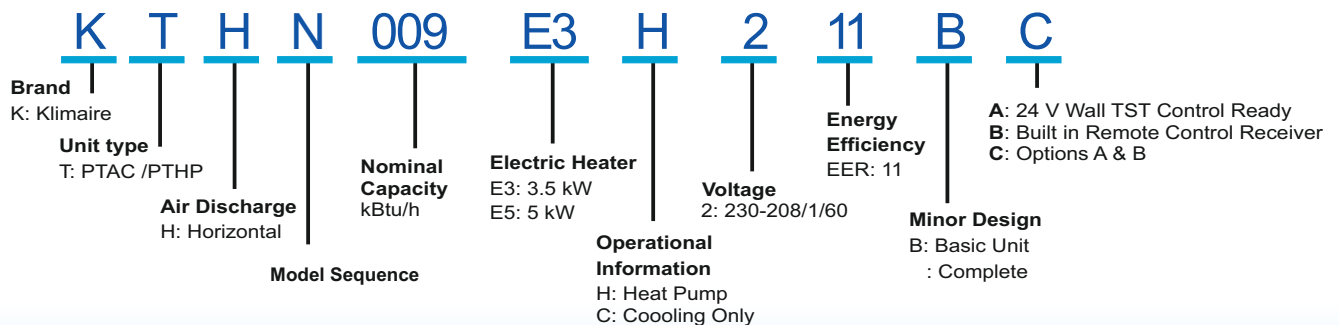

Specs - KTHN Series - Air Conditioner

Klimaier Model Number			KTHN009E3C211-BC	KTHN012E3C211-BC	KTHN015E5C210-BC
MPN			MWDUP-09EEN1-MK3	MWDUP-12EEN1-MJ5	MWDUP-15EEN1-MI5
Power Supply		Ph-V-Hz	230-208 / 1 / 60	230-208 / 1 / 60	230-208 / 1 / 60
Cooling	Capacity	Btu/h	9200/9000	12000/11800	14700/14500
	Input	W	814/796	1142/1124	1547/1526
	Current	A	3.54/3.83	4.97/5.4	6.73/7.34
	EER	Btu/h/W	11,3	10,5	9,5
Heating (PTC)	Capacity	Btu/h	10900/8900	10900/8900	10900/8900
	Input	W	3519/2850	3519/2850	4702/3794
	Current	A	15.30/13.70	15.3/13.7	15.30/13.70
Heater		kW	3.5	3.5	5.0
Starting Current		A	18	25,9	39
Indoor Fan Motor	FLA / Output	A / W	0.155 / 21	0.155 / 21	0.155 / 21
Outdoor Fan Motor	FLA / Output	A / W	0.35 / 37	0.41 / 58	0.41 / 58
Min. Circuit Ampacity	MCA	A	20	20	25
Compressor	Type	Type	Rotary	ROTARY	ROTARY
	Capacity	Btu/h	7745/7847.6	10714/10850	13648
	Input	W	770/785	1045/1050	1310
	Rated current (RLA)	A	3.75/3.5	5.0/4.55	6,35
	Locked rotor Amp (LRA)	A	18	25,9	34,5
	Capacitor	uF	25	35	35
Indoor Side Fan Motor	Input	W	35,5	35,5	35,5
	Capacitor	uF	1	1	1
	Speed (Hi/Mi/Lo)	rpm	1110/1070/1040	1110/1070/1040	1110/1070/1040
Outdoor Side Fan Motor	Input	W	69	87	87
	Capacitor	uF	3	3	3
	Speed (Hi)	rpm	1400	1590	1590
Evaporator	Number of rows	n	2	3	3
	Number of circuits	n	2	3	4
Indoor Side Air Flow (Hi/Mi/Lo)		cfm	435/418/394	435/424/412	424/406/394
Indoor Side Noise Level (Hi/Mi/Lo)		dB(A)	50/48/46	53/50/45	53/50/45
Condenser	Air flow	cfm	435/417/394	435/423/411	388/376/364
	Number of rows	n	2	3	3
	Number of circuits	n	2	3	3
Outdoor Side Noise Level (Hi)		dB(A)	63	66	66
Refrigerant Type	Type / Qty.	oz	R410A /21.2 oz	R410A / 26.9 oz	R410A /28.9 oz
Design Pressure		psig	540/300	540/300	540/300
Connection wiring		AWG	12AWGx3	12AWGx3	12AWGx3
Plug Type		Type	LCDI 6-20P	LCDI 6-20P	LCDI 6-30P
Control Type		Type	Electronic Control	Electronic Control	Electronic Control
Operation Temp	Indoor (Cooling/Heating)	°F	62°F-90°F / 32°F-80°F	62°F-90°F / 32°F-80°F	62°F-90°F / 32°F-80°F
	Outdoor (Cooling/Heating)	°F	64°F-109°F / 23°F-76°F	64°F-109°F / 23°F-76°F	64°F-109°F / 23°F-76°F
Application Area (Cooling EPA)		sq. ft	350-400	450-500	550-700
Dimension	(W*D*H)	in	42x21x16	42x21x16	42x21x16
Net/Gross weight		lb	104.7/130.1	117.9/143.3	117.9/143.3

Specs - KTHN Series - Air Conditioner & Heat Pump

Klimaite Model Number			KTHN009E3H211-BC	KTHN012E3H211-BC	KTHN015E5H210-BC
MPN			KMWDUP-09AEN1-MK3	KMWDUP-12AEN1-MJ5	KMWDUP-15AEN1-MI6
Power Supply		V / ph / Hz	230-208 / 1 / 60	230-208 / 1 / 60	230-208 / 1 / 60
Cooling	Capacity	Btu/h	9000/8800	12000/11800	14700/14500
	Input	W	796/778	1142/1124	1531/1510
	Current	A	3.46/3.75	4.97/5.4	6.66/7.26
	EER	Btu/h/W	11,3	10,5	9,6
Heating (Heat pump)	Capacity	Btu/h	8100/7900	10800/10500	13500/13200
	Input	W	716/699	990/963	1323/1294
	Current	A	3.04/3.28	4.3/4.63	5.74/6.2
	COP	W/W	3,4	3,2	3,0
Heating (PTC)	Capacity	Btu/h	10900/8900	10900/8900	10900/8900
	Input	W	3519/2850	3519/2850	4702/3794
	Current	A	15.3/13.7	15.3/13.7	15.3/13.7
Heater		kW	3.5	3.5	5.0
Starting current		A	18	25,9	39
Indoor fan motor	FLA / Output	A / W	0.155 / 21	0.155 / 21	0.155 / 21
Outdoor fan motor	FLA / Output	A / W	0.35 / 37	0.41 / 58	0.41 / 58
Min. Circuit Ampacity	MCA	A	20	20	25
Compressor	Type	Type	ROTARY	ROTARY	ROTARY
	Capacity	Btu/h	7745/7847.6	10714/10850	13648
	Input	W	770/785	1045/1050	1310
	Rated current (RLA)	A	3.75/3.5	5.0/4.55	6,35
	Locked Rotor Amp (LRA)	A	18	25,9	34,5
	Capacitor	uF	25	35	35
Indoor Side Fan Motor	Input	W	35,5	35,5	35,5
	Capacitor	uF	1	1	1
	Speed (Hi/Mi/Lo)	rpm	1110/1070/1040	1110/1070/1040	1110/1070/1040
Outdoor Side Fan Motor	Input	W	69	87	87
	Capacitor	uF	3	3	3
	Speed (Hi)	rpm	1400	1590	1590
Evaporator	Number of Rows	n	2	3	3
	Number of Circuits	n	2	3	4
Indoor Side Air Flow (Hi/Mi/Lo)		cfm	435/418/394	435/424/412	424/406/394
Indoor Side Noise Level (Hi/Mi/Lo)		dB(A)	50/48/46	53/50/45	53/50/45
Condenser	Air flow	cfm	435/417/394	435/423/411	423/405/394
	Number of Rows	n	2	3	3
	Number of Circuits	n	2	3	3
Outdoor Side Noise Level (Hi)		dB(A)	61	66	66
Refrigerant type	Type	oz	R410A / 24.7 oz	R410A / 31.4 oz	R410A / 37.0 oz
Design Pressure		psig	540/300	540/300	540/300
Connection Wiring		AWG	12AWGx3	12AWGx3	12AWGx3
Plug Type		Type	LCDI 6-20P	LCDI 6-20P	LCDI 6-30P
Control Type		Type	Electronic Control	Electronic Control	Electronic Control
Operation Temp	Indoor (Cooling/Heating)	°F	62°F-90°F / 32°F-80°F	62°F-90°F/32°F-80°F	62°F-90°F/32°F-80°F
	Outdoor (Cooling/Heating)	°F	64°F-109°F / 23°F-76°F	64°F-109°F / 23°F-76°F	64°F-109°F / 23°F-76°F
Application Area (Cooling EPA)		sq. ft	350-400	450-500	550-700
Unit Dimensions (W*D*H)		in	42x21x16	42x21x16	42x21x16
Net/Gross Weight		lb	106.9/132.3	117.9/143.3	120/145.5

Foldable sleeve



Stamped aluminum grille



Drain Kit



Architectural grille



Wall sleeve dimensions

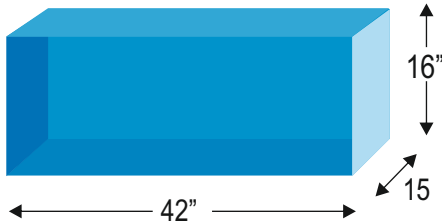

**Cord plug and wall outlet
Afcı cord included**

Perpendicular

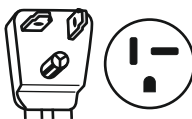

20 AMP (Optional)

Large Tandem

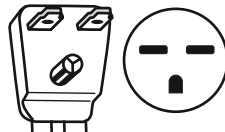

25 AMP
(208 / 230V)

**Minimum wall sleeve
Opening**

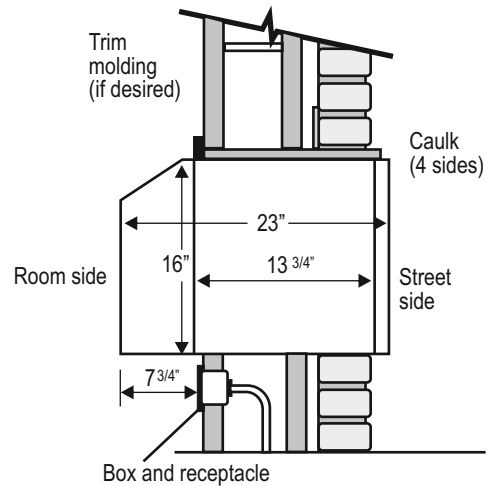

Warranty



PTAC AND **PTH**
UNITS

KTHN
Series



2190 NW 89 Place, Doral, FL 33172 - USA

Tel: (305)594-4972 Fax (305) 499-4378

www.klima.com sales@klima.com

KLIMAIRE®

The Klima logo is a registered Trademark of Klima Products, Inc.
Copyright 2015 Klima Products, Inc.